

# KBPC6005 thru KBPC610

## 6.0 A Single-Phase Silicon Bridge Rectifier

Rectifier Reverse Voltage 50 to 1000V



### Features

- This series is UL listed under the Recognized Component Index
- High temperature metallurgically bonded internal rectifiers
- Typical  $I_r$  less than  $.1 \mu A$
- The plastic material used carries Underwriters Laboratory flammability recognition 94V-0
- High temperature soldering guaranteed  $265^\circ C / 10$  seconds at 5 lbs (2.3kg) tension

### Mechanical Data

Case: Voil-free plastic package  
 Terminals: Plated leads solderable per MIL-STD-202, Method 208  
 Mounting: Thru hole for #6 screw  
 Mounting position: Any  
 Weight: 3.8 grams (approx)

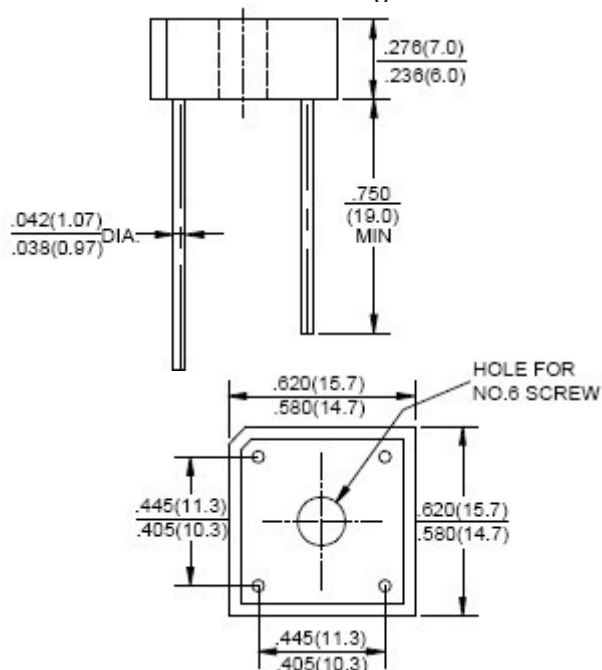

### Maximum Ratings & Thermal Characteristics

Rating at  $25^\circ C$  ambient temperature unless otherwise specified, Resistive or Inductive load, 60 Hz.  
 For Capacitive load derate current by 20%.

Parameter	Symbol	KBPC 6005	KBPC 601	KBPC 602	KBPC 604	KBPC 606	KBPC 608	KBPC 610	unit
Maximum repetitive peak reverse voltage	VRRM	50	100	200	400	600	800	1000	V
Maximum RMS bridge input voltage	VRMS	35	70	140	280	420	560	700	V
Maximum DC blocking voltage	VDC	50	100	200	400	600	800	1000	V
Maximum average forward rectified output current $T_c = 75^\circ C (1)$	IF(AV)	6.0							A
Peak forward surge current single sine-wave superimposed on rated load (JEDEC Method)	IFSM	125							A
Rating for fusing ( $t < 8.3ms$ )	$I^2 t$	10							$A^2 sec$
Typical thermal resistance per element (2)	ReJA	9.4							$^\circ C / W$
Typical junction capacitance per element (3)	Cj	55							pF
Operating junction and storage temperature range	TJ, TSTG	-55 to + 150							$^\circ C$

### Electrical Characteristics

Rating at  $25^\circ C$  ambient temperature unless otherwise specified. Resistive or Inductive load, 60Hz.  
 For Capacitive load derate by 20 %.

Parameter	Symbol	KBPC 6005	KBPC 601	KBPC 602	KBPC 604	KBPC 606	KBPC 608	KBPC 610	Unit
Maximum instantaneous forward voltage drop per leg at 3.0A	VF	1.1							V
Maximum DC reverse current at rated DC blocking voltage per element $T_A = 25^\circ C$ $T_A = 100^\circ C$	IR	10 1000							$\mu A$

**Notes:** (1) Mounted on metal chassis.  
 (2) Non-repetitive, for  $t > 1ms$  and  $< 8.3ms$ .  
 (3) Measured at 1.0MHz and applied reverse voltage of 4.0V DC.

**Rating and Characteristic Curves** (  $T_A=25^{\circ}\text{C}$  Unless otherwise noted )  
**KBPC6005 thru KBPC610**

**Fig. 1 Derating Curve for Output Rectified Current**

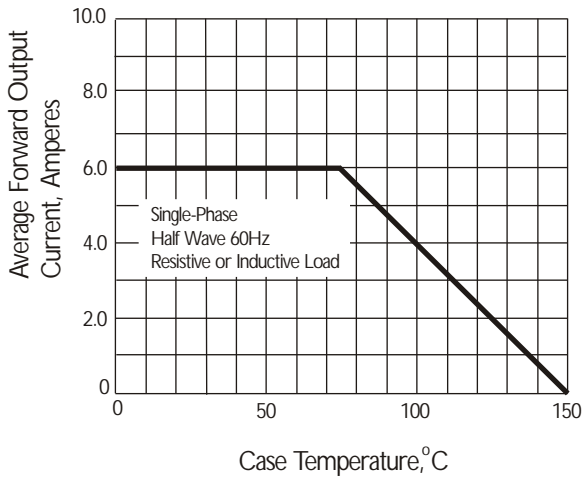

**Fig. 2 Maximum Non-repetitive Peak Forward Surge Current**

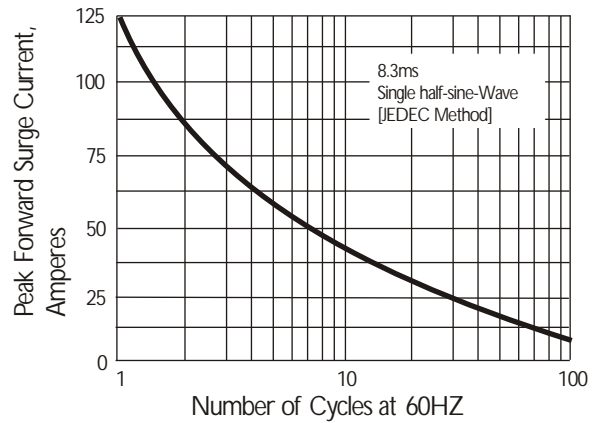

**Fig. 3 Typical Instantaneous Forward Characteristics**

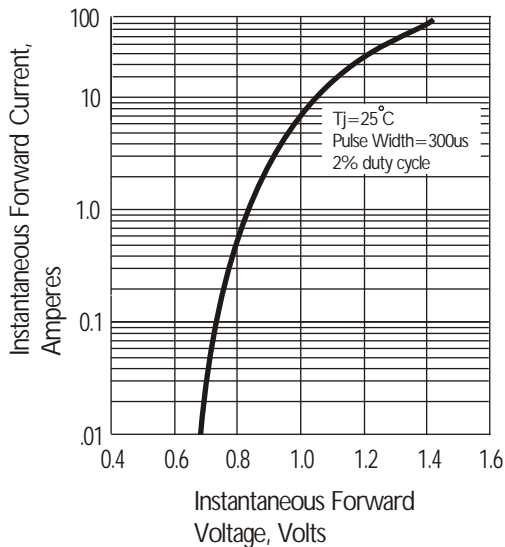

**Fig. 4 Typical Reverse Characteristics**

